



Most Widely Accepted and Trusted

ICC-ES Report

ESR-1218

ICC-ES | (800) 423-6587 | (562) 699-0543 | www.icc-es.org

Reissued 12/2015
This report is subject to renewal 12/2017.

DIVISION: 07 00 00—THERMAL AND MOISTURE PROTECTION
SECTION: 07 72 26—RIDGE VENTS

REPORT HOLDER:

BLOCKSOM & CO.

450 ST. JOHNS ROAD, #710
MICHIGAN CITY, INDIANA 46360

EVALUATION SUBJECT:

ROOF SAVER RIDGE VENT FOR ATTIC VENTILATION



Look for the trusted marks of Conformity!

“2014 Recipient of Prestigious Western States Seismic Policy Council (WSSPC) Award in Excellence”



A Subsidiary of

ICC-ES Evaluation Reports are not to be construed as representing aesthetics or any other attributes not specifically addressed, nor are they to be construed as an endorsement of the subject of the report or a recommendation for its use. There is no warranty by ICC Evaluation Service, LLC, express or implied, as to any finding or other matter in this report, or as to any product covered by the report.



ICC-ES Evaluation Report**ESR-1218**

Reissued December 2015

This report is subject to renewal December 2017.www.icc-es.org | (800) 423-6587 | (562) 699-0543

A Subsidiary of the International Code Council®

**DIVISION: 07 00 00—THERMAL AND MOISTURE
PROTECTION****Section: 07 72 26—Ridge Vents****REPORT HOLDER:****BLOCKSOM & CO.**
450 ST. JOHNS ROAD, #710
MICHIGAN CITY, INDIANA 46360
(219) 874-3231www.roofsaver.com
aswan@blocksom.com**EVALUATION SUBJECT:****ROOF SAVER RIDGE VENT FOR ATTIC VENTILATION****ADDITIONAL LISTEES:****AIR VENT, INC.**
4117 PINNACLE POINT DRIVE, SUITE 400
DALLAS, TEXAS 75211
SUBJECT: *EASY-UP ROLLED RIDGE VENT***BERGER BUILDING PRODUCTS, INC.**
805 PENNSYLVANIA BOULEVARD
FEASTERVILLE, PENNSYLVANIA 19053
SUBJECT: *PRO-MASTER ROLLED RIDGE VENT***TRI-BUILT MATERIAL GROUP LLC**
POST OFFICE BOX 70
RUTHERFORD, NEW JERSEY 07070
SUBJECT: *AIRFLO ROLLED RIDGE VENT***QUALITY EDGE, INC.**
2712 WALKENT DRIVE
WALKER, MICHIGAN 49544
SUBJECT: *TRUAIR RIDGE VENT***1.0 EVALUATION SCOPE****Compliance with the following codes:**

- 2006 *International Building Code*® (IBC)
- 2006 *International Residential Code*® (IRC)

Properties evaluated:

- Ventilation of attic spaces
- Weather resistance
- Wind uplift resistance
- Fire classification

2.0 USES

Roof Saver Ridge Vent is a flexible material that is intended to be installed, in conjunction with eave, cornice or soffit vents, for the purpose of providing natural ventilation of enclosed attic and rafter spaces.

3.0 DESCRIPTION**3.1 Ridge Vent:**

Roof Saver Ridge Vent is a flexible, single-layer, three-dimensional black matting which is manufactured from natural fibers laid on a polyester mat and joined by latex binding agents. The material has a nominal thickness of $\frac{3}{4}$ inch (19.1 mm) and a nominal weight of 5.0 ounces per square foot (1525 g/m²), and is manufactured in rolls measuring 7.0, 8.5, 10.5 and 11.5 inches (178, 216, 267 and 292 mm) wide by 20 or 50 feet (6096 or 15 240 mm) long. The vent is intended for use with asphalt roof shingle roof coverings. The net free ventilation area of the vent, when installed with a $\frac{3}{4}$ -inch-high (19.1 mm) opening, is 15.2 square inches per lineal foot (32.173 mm²/m). The Roof Saver Ridge Vent is also sold by the additional listees noted in this report, under the product names noted for each of the listees.

3.2 Wind Deflector:

The drip-edge wind deflector supplied by the installer must be constructed of minimum 0.019-inch-thick (0.48 mm), aluminum complying with ASTM B 209, with a 2.5-inch (64 mm) horizontal leg, a $\frac{7}{8}$ -inch-high (22.2 mm) vertical leg and a $\frac{1}{4}$ -inch (6.4 mm), 45-degree extension. See Figure 2.

4.0 INSTALLATION

Installation of Roof Saver Ridge Vent must comply with this report and the published manufacturer's instructions. The manufacturer's published installation instructions must be available at the jobsite at all times during installation.

4.1 General:

The minimum roof slope must be 3 units vertical in 12 units horizontal (3:12) (25%). The maximum roof slope must be 12:12 (100%) where there is a ridge board and 20:12 (167%) where there is no ridge board. On roofs with no ridge board, the minimum nominal width of the opening, measured horizontally, must be 1 inch (25.4 mm) on each side of the roof ridge. On roofs with a ridge board, the nominal width of the opening must be 1 inch (25.4 mm) on each side of the ridge board. The last 12 inches (305 mm) of sheathing, inside the exterior wall line at each end of the ridge, must be left uncut. The ridge vent must be unrolled over the roof shingles and positioned to completely cover

the opening. Shorter lengths of roof vent material are joined by butting the ends together, with no gaps between sections.

The ridge vent material must be completely covered by the ridge shingles. Ridge shingles are nailed in place with 11 gage [0.120 inch (3.05 mm) shank diameter] corrosion-resistant roofing nails, with minimum $\frac{3}{8}$ -inch-diameter (9.5 mm) heads. The nail length must be sufficient to penetrate into the sheathing $\frac{3}{4}$ inch (19.1 mm) or through the sheathing, whichever is less. The nails must be installed on each side of the vent at spacings not exceeding 5 inches (127 mm) on center, or closer where required by the ridge shingle manufacturer, with a minimum of two nails per ridge shingle. Overlap of the ridge shingles must be in accordance with the roof covering manufacturer's instructions. The ridge shingles must be installed so that a minimum $\frac{3}{4}$ inch (19.1 mm) of clear space remains between the underside of the ridge shingles and the top surface of the roof shingles. See Figure 1 for typical installation details. The ridge vent, installed as described in this section, is limited to installation in areas where the maximum basic wind speed (3-second gust) is 80 miles per hour (129 km/h), on structures a maximum of 40 feet (12192 mm) in height, in Exposure B areas. For use in other areas, see Section 4.2.

4.2 Wind Deflector:

The ridge vent may be used in areas where the maximum basic wind (3-second gust) speed is 80 miles per hour (129 km/h), on structures a maximum of 40 feet (12 192 mm) in height, in Exposure C or D areas, when an aluminum wind deflector is installed. The wind deflector described in Section 3.2 must be nailed in place with 11 gage [0.120 inch (3.05 mm) shank diameter] corrosion-resistant roofing nails, with minimum $\frac{3}{8}$ -inch-diameter (9.5 mm) heads over the field shingles on each side of an opening cut into the roof sheathing material on each side of the roof ridge, as shown in Figures 1 and 2.

5.0 CONDITIONS OF USE

The Roof Saver Ridge Vent described in this report complies with, or is a suitable alternative to what is specified in, those codes listed in Section 1.0, subject to the following conditions:

- 5.1 The ridge vent is manufactured, identified and installed in accordance with this report and the manufacturer's published installation instructions, and the applicable code. In the event of a conflict between the manufacturer's instructions and this report, this report governs.
- 5.2 The ridge vent is limited to installation on roofs with the minimum and maximum slopes set forth in Section 4.1.
- 5.3 The ridge vent, installed without the wind deflector described in Section 4.2, is limited to installation in areas set forth in Section 4.1.
- 5.4 The minimum ventilation area and required percentage of area between eave or cornice vents and the opening provided by the ridge vent required for the concealed spaces must be calculated in accordance with the requirements of the applicable code.
- 5.5 The roof diaphragm nailing requirements must be addressed and the vent installation approved by the code official.
- 5.6 The ridge vent must be covered with asphalt roof shingles in accordance with the applicable code. The ridge vent is permitted for use with Class A, B, or C or nonclassified asphalt shingle roof coverings.

6.0 EVIDENCE SUBMITTED

- 6.1 Data in accordance with the ICC-ES Acceptance Criteria for Attic Vents (AC132), dated February 2010.
- 6.2 Report containing results of testing performed in accordance with UL790 (modified).

7.0 IDENTIFICATION

Each carton or package of the Ridge Vent must bear the Blocksom & Co. name and address or the name and address of one of the additional listees noted in this report. Each carton or package must also bear the product name, the size, roof covering classification information, and the evaluation report number (ESR-1218), and must include the installation instructions.

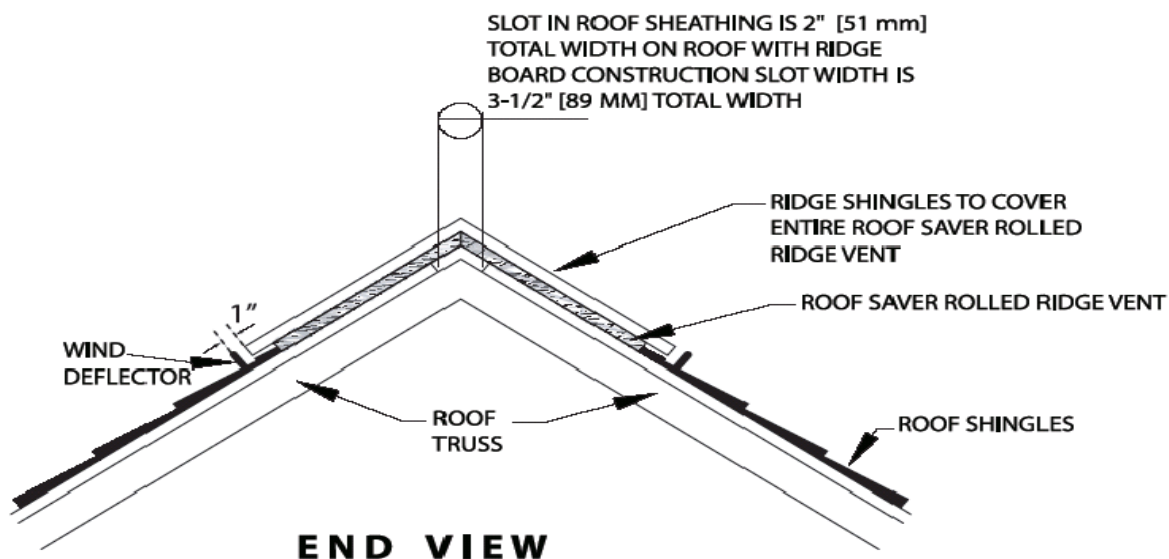
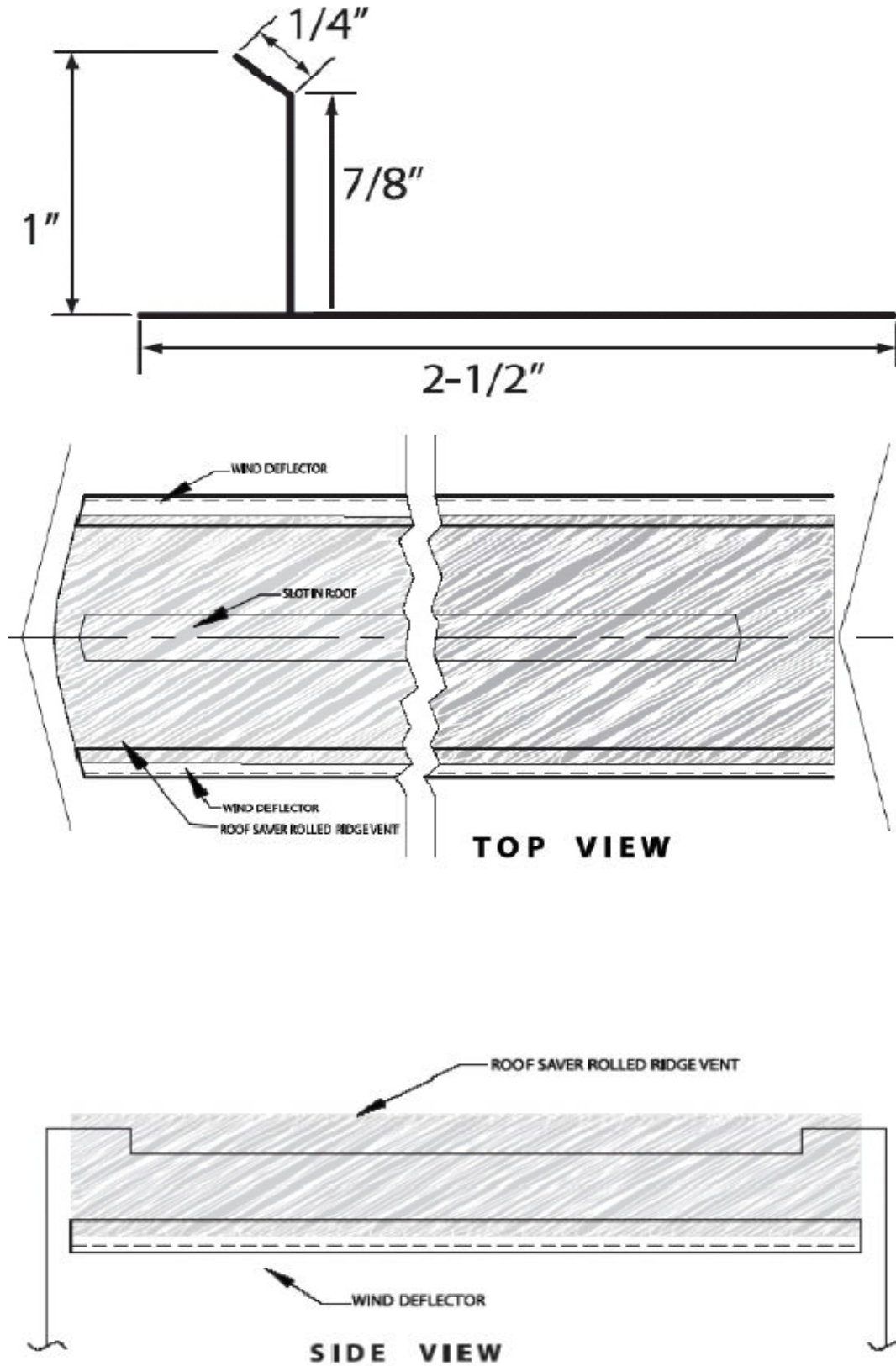

FIGURE 1—TYPICAL APPLICATION DETAILS



For SI: 1 inch = 25.4 mm.

FIGURE 2—WIND DEFLECTOR INSTALLATION